

Alepo Home Subscriber Server

Introduction

Alepo's Home Subscriber Server (HSS) is an integral part of any LTE or IMS core network. By centralizing all subscriber information, the Alepo HSS separates signalling from policy, creating a more streamlined, high-performing network.

A critical element of LTE networks, the HSS communicates with the rest of the network to provide subscriber profile and authentication information. Communicating primarily with the Mobility Management Entity (MME) via the S6a interface, the HSS is a database of subscriber information that provides authentication and device profiles, authentication credentials, and location and service information to the network via diameter protocol.

Functions of the Alepo HSS

Centralization of Subscribers

The Alepo HSS contains all subscriber information, including service profiles, authentication ciphering, and subscription state. The streamlined architecture of LTE enables this information to be stored in a single node, which signals to the rest of the network to grant, restrict, or alter access. Centralizing this database increases performance by managing subscriber info from a central location, enabling greater network efficiency and ease of reporting and product creation.

Provisioning, Activation, and Barring

The Alepo HSS supports the provisioning, activation, and barring of SIMs. SIM cards and their authentication keys may be imported in batches into the HSS or provisioned dynamically using an API. An API is also available for SIM card activation by an external CRM or billing system. A barring API allows the barring and unbarring of services and features.

Alepo HSS at a Glance

Performance Benchmarks	2000 TPS, 99.999% availability
Standards Compliance	3GPP TS 29.272 Rel. 9, Rel. 10
Network Access Types	LTE

Subscriber Hierarchies

The Alepo HSS uses a Lightweight Directory Access Protocol (LDAP) interface to create a hierarchical database of subscribers and subscriptions. The HSS ensures high performance, high capacity, low latency, and endless scalability by: being schema and structure agnostic, providing real-time script, connection pooling, and SSL encryption.

Increase Customer Satisfaction & Reduce Churn

If the Alepo HSS is combined with a AAA Server, it can aid in the inter-working of an LTE network with legacy or concurrent services as well as supporting roaming to non-3GPP networks, to help service providers grow their network quickly. It can also communicate with a WiFi infrastructure, helping providers further monetize and relieve congestion with offload.

Highlights of the Alepo HSS



Vendor Neutral and Standards Compliant

Interoperable with any best-of-breeds network, preventing vendor lock-in, enabling an operator to deploy a multi-vendor network for better price and performance, and reducing both up-front and long-term network costs. With Alepo's HSS, providers are assured of a product capitalizing on Alepo's years of integration experience and continued innovations to help providers remain agile, ready to grow and shift as quickly as the market.



Easy to Use

Alepo's HSS interface is engineered to be as intuitive yet robust as possible. The HSS interface is completely web-based, meaning that providers can access network information from anywhere in the world. And with both an Agent and Configuration Manager Portal, technical and business activities are separated into two streamlined interfaces. All subscriber information, including service profiles, authentication ciphering, and subscription state in a central location, is centralized - simplifying your reporting and product creation.



Lightweight

The Alepo HSS is a lightweight product built specifically for LTE, without legacy technologies weighing it down, helping operators

to relieve their data centre load. The HSS contains all subscriber information, stored in a single node, which signals to the rest of the network to grant, restrict, or alter access. Centralizing this database increases performance, enabling greater network efficiency.



Scalable and Reliable

Alepo's system is endlessly and easily scalable. By simply adding additional servers, the system can expand to fit the network's growing needs. And there's no need to replace existing hardware to grow, simply adding additional equipment will leverage existing hardware and avoid the risk of replacing functioning nodes. And with equally easy load balancing, the system remains high performing and extremely reliable, offering redundancy and failover across all nodes.



High Performance

Centralizing and streamlining network signalling relies on a powerful and speedy HSS to reach its full potential. Alepo's HSS boasts market-leading speed and reliability, achieving an average of 2,000 TPS per node and 99.999% availability. Such a high level of performance ensures providers of an extremely fast network that eschews downtime and network clogging, increasing customer satisfaction through a consistent and lightning fast service.

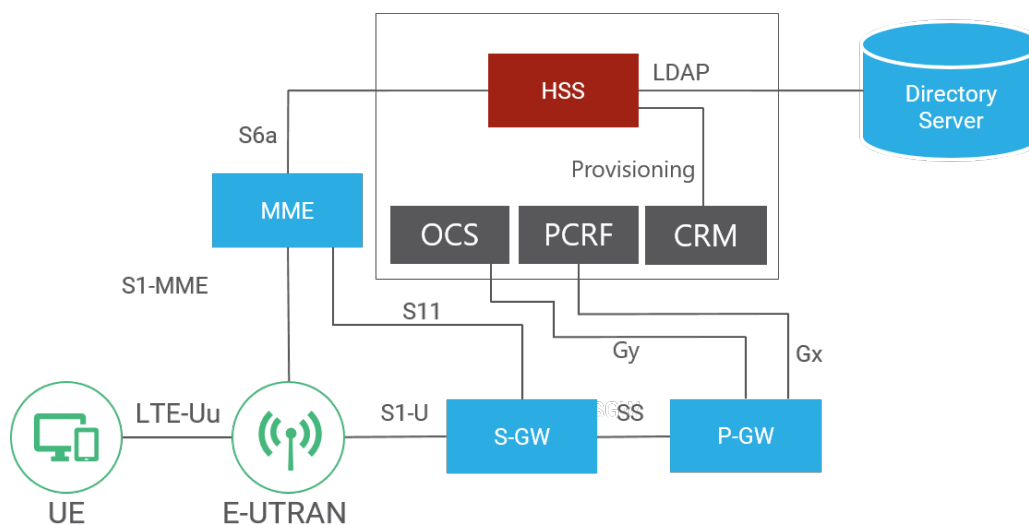

Corporate HQ & North America Sales
Austin, TX, USA
sales@alepo.com

LATAM Regional Sales
Bogota, Colombia
latam.sales@alepo.com

APAC Regional Sales
Mumbai, India
apac.sales@alepo.com

Research Development
Pune, India